

TECHNICAL RECOMMENDATIONS FOR HIGHWAYS

TRH 21: 2009

HOT MIX RECYCLED ASPHALT

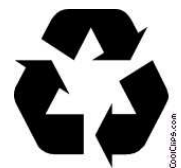

July 2009

ACKNOWLEDGEMENTS

In compiling this manual the input of the Road Pavements Forum Task Group on HMA Recycling consisting of the following members is acknowledged:

| | |
|--------------------|------------------------|
| Adreo Brits | GPTRW |
| Gary Catin | Rand Roads |
| Trevor Distin | Sabita |
| Bennie Greyling | Much Asphalt |
| Tony Lewis | Independent consultant |
| Rob Lindsay | KZN DoT |
| Eric Lathleiff | eThekwini Municipality |
| Herman Marais | Much Asphalt |
| Krishna Naidoo | eThekwini Municipality |
| Wynand Nortje | National Asphalt |
| Derick Pretorius | Arcus Gibb |
| Dennis Rossmann | SANRAL |
| Nicol van der Walt | Independent consultant |
| Benoit Verhaeghe | CSIR |

Sabita is also gratefully acknowledged for the sponsoring of the revision of this document.

Figures 2, 3, 4 and 5 are reprinted by kind permission of National Asphalt Pavement Association (NAPA) (USA).

PREFACE

TECHNICAL RECOMMENDATIONS FOR HIGHWAYS (TRH) are written for the practising engineer and describe current recommended practice in selected aspects of highway engineering.

The first draft of TRH 21 *Hot Mix Recycling* was produced in 1996, based on the latest technology used at that time. Since then there have been significant developments in hot mix asphalt recycling and the current updated draft entitled "**TRH 21: 2009 Hot mix Asphalt Recycling**" incorporates these advances, based on information gathered from around the world on best practise in this field.

A draft copy of the revised TRH 21 document was placed on Sabita's website for a period of three months, to encourage comment from local practitioners. It was then circulated to AAPA, NAPA and EAPA for peer review before the final document was published.

DISCLAIMER

Considerable effort has been made to ensure the accuracy and reliability of the information contained in this publication. However, neither the publisher of this document nor any of its contributors can accept any liability whatsoever for any loss, damage or injury resulting from the use of this information.

LIST OF COMPANION TRH DOCUMENTS

| | |
|--------|--|
| TRH 1 | Prime coat and bituminous curing membranes |
| TRH 3 | Design and construction of surfacing seals |
| TRH 4 | Structural design of flexible pavements for interurban and rural roads |
| TRH 5 | Statistical concepts of quality control and their application in road construction |
| TRH 6 | Nomenclature and methods for describing the condition of asphalt pavements |
| TRH 7 | Use of bitumen emulsions in the construction and maintenance of roads |
| TRH 8 | Selection and design of hot mix asphalt surfacings for highways |
| TRH 9 | Construction of road embankments |
| TRH 10 | Design of road embankments |
| TRH 11 | Guidelines for the conveyance of abnormal loads |
| TRH 12 | Bituminous pavement rehabilitation design |
| TRH 13 | Cementitious stabilisers in road construction |
| TRH 14 | Guidelines for road construction materials |
| TRH 15 | Subsurface drainage for roads |
| TRH 16 | Traffic loading for pavement and rehabilitation design |
| TRH 17 | Geometric design of rural roads |
| TRH 18 | Investigation, design, construction and maintenance of road cuttings |
| TRH 19 | Standard nomenclature and methods for describing the condition of jointed concrete pavements |
| TRH 20 | The structural design, construction and maintenance of unpaved roads |
| TRH 22 | Pavement management systems |

LIST OF COMPANION TMH DOCUMENTS

| | |
|--------|---|
| TMH 1 | Standard methods of testing road construction materials |
| TMH 2 | National standard for the spraying performance of binder distributors |
| TMH 3 | Traffic axle load surveys for pavement design |
| TMH 5 | Sampling methods for road construction materials |
| TMH 6 | Special methods for testing roads |
| TMH 8 | Verkeerstelling prosedures vir buitestedelike paaie |
| TMH 9 | Pavement management systems |
| TMH 10 | Manual for completion of as-built material data sheets |
| TMH 12 | Visual assessment manual for unsealed roads. |

LIST OF COMPANION SABITA DOCUMENTS

| | |
|-----------|---|
| Manual 1 | Construction of bitumen rubber seals |
| Manual 2 | Bituminous products for road construction and maintenance |
| Manual 5 | Guidelines for the manufacture and construction of hot mix asphalt |
| Manual 7 | SuperSurf: Economic warrants for surfacing unpaved roads |
| Manual 8 | Guidelines for the safe and responsible handling of bituminous products |
| Manual 9 | Bituminous surfacings for temporary deviations |
| Manual 10 | Appropriate standards for bituminous surfacings |
| Manual 11 | Labour enhanced construction for bituminous surfacings |
| Manual 12 | Methods and procedures – Labour enhanced construction for bituminous surfacings |
| Manual 13 | LAMBS – The design and use of large aggregate mixes for bases |
| Manual 14 | GEMS – The design and use of granular emulsion mixes |
| Manual 16 | REACT – Economic analysis for short-term rehabilitation actions |
| Manual 17 | The design and use of porous asphalt mixes |
| Manual 18 | Appropriate standards for the use of sand asphalt |
| Manual 19 | Guidelines for the design, manufacture and construction of bitumen rubber asphalt wearing courses |
| Manual 20 | Sealing of active cracks in road pavements |
| Manual 21 | ETB – The design and use of emulsion treated bases |
| Manual 22 | Hot mix paving in adverse weather |
| Manual 24 | User guide for the design of hot mix asphalt |
| Manual 25 | Quality management in the handling and transport of bituminous binders |
| Manual 26 | Interim guidelines for primes and stone precoating fluids |
| Manual 27 | Guideline for thin layer hot mix asphalt wearing courses on residential streets |

COMPANION ASPHALT ACADEMY GUIDELINE DOCUMENTS

| | |
|------|---|
| TG 1 | Technical Guideline: The use of modified binders in road construction |
| TG 2 | Technical Guideline: Bitumen stabilised materials |
| TG 3 | Technical Guideline: Asphalt reinforcement for road construction |

LIST OF TABLES AND FIGURES

| Tables | | Page |
|--------------------|--|-----------------|
| Table 1.1 | Estimated % of total quantities of RA used in various countries during 2005 | 9 |
| Table 7.1 | Typical RA fractions and uses in recycled asphalt mixes | 24 |
| Table 8.1 | Guideline for binder grade and tests on quality of the aggregate in the RA | 26 |
| Table 8.2 | Preparation and testing of the RA before carrying out the preliminary mix design | 27 |
| Table 8.3 | Typical binder blending chart | 29 |
| Table 8.4 | Laboratory mixing time for mixes containing various proportions of RA | 28 |
| Table 8.5 | Guidelines for maximum RA contents in various asphalt mix types | 30 |
| Table 9.1 | Typical maximum RA capabilities of different types of mixing plant | 35 |
| Table 9.2 | Mixing plant requirements and factors that influence RA content | 36 |
| Figures | | Page |
| Figure 3.1 | The hot mix recycling process | 14 |
| Figure 7.1 | Phased approach to stockpiling RA | 25 |
| Figure 9.1 | Pugmill recycling using a separate weigh hopper | 32 |
| Figure 9.2 | Introducing the RA into the bucket elevator | 33 |
| Figure 9.3 | Counter-flow drum mixer with separate after-mixer | 34 |
| Figure 9.4 | Double-drum type mixing plant | 35 |
| Figure 10.1 | Influence of bitumen price and RA content on HMA price | 38 |

LIST OF CONTENTS

| Chapter | TITLE | Page |
|-----------|---|------|
| 1 | Introduction | 8 |
| 1.1 | Status of hot mix asphalt recycling worldwide | 8 |
| 1.2 | History of hot asphalt recycling in RSA | 9 |
| 1.3 | Definition of RA | 9 |
| 2 | Layout of the document | 11 |
| 3 | Asphalt recycling processes | 12 |
| 3.1 | Principles of hot mix asphalt recycling | 12 |
| 4 | Obstacles and solutions to hot-mix asphalt recycling | 15 |
| 5 | Factors that influence availability and quality of RA | 16 |
| 5.1 | Geographical distribution of asphalt pavements in RSA | 16 |
| 5.2 | Distribution of asphalt mix types | 16 |
| 5.3 | Other factors influencing RA quality and selection | 17 |
| 6 | Investigation of RA sources | 19 |
| 6.1 | Desk study | 19 |
| 6.2 | Field investigations | 20 |
| 7 | Reclaiming, preparing & stockpiling RA | 22 |
| 7.1 | Milling RA | 22 |
| 7.2 | Stockpiling RA | 22 |
| 8 | Mix design procedures | 26 |
| 8.1 | Preliminary mix design | 26 |
| 8.2 | Main mix design | 29 |
| 9 | Mixing plant requirements | 31 |
| 9.1 | Mixing plant types and capabilities | 31 |
| 9.2 | Cold feed systems | 36 |
| 10 | Quality control of hot mix recycled asphalt | 37 |
| 11 | Economic considerations of hot mix recycled asphalt | 38 |
| 12 | Occupational health, safety and environmental considerations | 40 |
| 13 | References | 41 |
| 14 | Appendices: Case studies | 43 |

1 INTRODUCTION

These guidelines cover all the main aspects of hot mix asphalt recycling, a process in which reclaimed asphalt is combined with new aggregate and new binder in a mixing plant to produce recycled hot mixed asphalt. Experience gathered in South Africa, as well as international experience, has been utilised wherever possible.

Reclaimed asphalt is commonly known in some countries as “RAP”, the acronym for “recycled asphalt pavement”. However, due to the possible confusion that “RAP” includes the full depth of the pavement, including the asphalt as well as the underlying pavement layers, the term “RA” is used in these guidelines as the acronym for “reclaimed asphalt”.

RA contains roughly 95% of high quality aggregate and 5% of aged bitumen, both valuable non-renewable resources. After many years of service the aged asphalt has most likely deformed or cracked as the aging process causes the binder to harden, making the asphalt brittle. However the aggregate quality will not have altered and the RA should be treated as a valuable asset of the State. In fact some authorities regard *in situ* asphalt as an alternative aggregate source, referring to it as a “linear quarry”. RA is sometimes referred to as “black aggregate” and virgin aggregate as “white aggregate”.

Most often the monetary value of this engineered product is worth more at the end of its design life than when it was first paved in the pavement. Just as important is to ensure that RA is reused in the most optimal way and is not for example downgraded for use as backfill material in trench reinstatements.

In the past, people have tended to associate the term “recycling” with a product that is “not as good as new”, or that is “second-hand” and not of the same quality as a product manufactured from virgin raw materials. Due to this misconception there has been a tendency for RA to be treated sub-optimally, or even as a waste product. This is certainly not the case, and recycled hot mixed asphalt mixes containing RA are subject to the same quality and performance requirements as mixes using all new materials.

Recycling asphalt pavements makes good sense from both economic and environmental points of view; the process enables petroleum and aggregate resources to be conserved, and saves landfill space that would otherwise have been taken up with the discarded asphalt. With the increasingly strong worldwide trend towards environmental issues, such as lifecycle inventories and carbon credits, the whole process of hot mix asphalt recycling makes good sense.

1.1 Status of hot-mix asphalt recycling worldwide

Since the mid 70s asphalt from existing road pavements has been used in the production of millions of tons of recycled mix that have the same performance characteristics as hot mixed asphalt made with all virgin materials.

The quantities of recycled hot mix asphalt have grown exponentially in many countries around the world. For instance in the USA about 80% of all reclaimed asphalt, or around 73 million tons per annum, is recycled as road making material¹, making it the most recycled engineered material in the USA. Hot mix asphalt recycling is routinely carried out in Europe, with RA properties being specified in a European Standard⁴. In the Far East, countries such as Japan recycle almost all the asphalt reclaimed from their roads, while in Taiwan there are regulations stipulating that all reclaimed asphalt is to be recycled in asphalt mixes. Various factors influence

the proportion of RA used in the manufacture of HMA from one country to the next; the main drivers being economics, dictated by the availability of suitable aggregates and the high cost of bitumen, by state policy, or by a mixture of these two main factors.

The estimated percentage of the total quantity of RA that is reused in the manufacture of hot mix asphalt in various countries is shown in Table 1.1.

Table 1.1 Estimated % of total quantity of RA used in various countries during 2005

| Country | % RA utilised |
|----------------|----------------------|
| South Africa | 5 |
| France | 13 |
| Australia | 50 |
| Netherlands | 75 |
| USA | 80 |
| Germany | 82 |
| Japan | 99 |

1.2 History of hot mix asphalt recycling in South Africa

Asphalt recycling was first used on major road projects in South Africa in the early 80's, when contracts such as the rehabilitation of National Route 3 through Van Reenen's Pass and the section of National Route 1 between Kraaifontein and Paarl³ were undertaken. In 1984 a Technical Working Group was formed under the auspices of the CSIR, comprising representatives from a broad spectrum of the road building industry. Several papers and guidelines covering hot asphalt recycling were produced during this period^{4,5,6}. These documents were used to provide information in the compilation of Draft TRH 21: 1996⁷.

Besides using hot mix asphalt recycling to produce asphalt base and surfacing layers for flexible pavements, the process was also used extensively in the 90's to provide a hot mix asphalt subbase under the concrete pavement on substantial stretches of the National Route 3 in KwaZulu Natal⁸.

However asphalt recycling using RA disappeared from the market during the mid 90's due to market related factors during this period. Given the dramatic increase in the cost of aggregates, fuel and bitumen in 2008, the viability of recycling RA makes good economic sense to ensure the competitiveness of asphalt pavements.

1.3 Definition of RAP

As explained previously in these guidelines, reclaimed asphalt is known as "RAP"; short for reclaimed asphalt pavement" in some countries, but to avoid confusion with other recycling processes that utilise material from other layers in the pavement besides the asphalt, the acronym "RA" is used to describe fragments of hot mixed asphalt that have been obtained from road pavements. RA can also be sourced from stockpiles of discarded asphalt sometimes found in the vicinity of asphalt mixing plants.

Most often RA is produced by milling machines, which mill out the asphalt layers in existing road pavements, usually as part of the pavement rehabilitation process. In fact milling machines have

been referred to as “mining machines” due to way in which they recover and granulate the asphalt from existing road pavements, similar to the way that quarrying is carried out to mine and crush rock sources. In this case the asphalt in the road can be likened to a “linear quarry”.

RA can also be produced by crushing slabs of asphalt that have been excavated from road pavements, and then crushed.

The European CEN Standard EN 13108-8², which also uses the acronym “RA” defines it as follows: “Reclaimed asphalt comprises asphalt reclaimed from milling road layers, by crushing slabs ripped up from asphalt pavements, lumps from slabs, and asphalt from reject and surplus production.”

The following, more detailed, definition of RA is given in Austroad's “*Framework specifications for asphalt recycling AP – T02*”¹¹.

“RAP shall be obtained from milling or excavation of existing asphalt pavements or stockpiles. RAP shall be crushed and screened as necessary to ensure a maximum size no greater than the maximum size of asphalt being produced, and to achieve a reasonably well graded, free flowing, and consistent product.

RAP shall be free of foreign material such as unbound granular base, broken concrete, crumbed rubber, or other contaminants. Asphalt containing tar shall not be used.

RAP shall be placed in separate stockpiles prior to use. RAP that has been stockpiled for some time shall be reprocessed, where necessary, to ensure that it is in a free flowing state at the time of use. Where representative sampling is required of stockpiled materials, the stockpiles should generally not exceed 500 tons”.

2 LAYOUT OF THE DOCUMENT

The document is set out to cover the most important aspects of hot mix asphalt recycling in a logical sequence:

- The process relies on sources of reclaimed asphalt, mostly milled from existing road pavement layers, and factors that influence the availability and quality of this material are covered in Chapter 3.
- Chapter 4 discusses factors that can hinder hot mix asphalt recycling, as well as ways to overcome these obstacles.
- Hot mix asphalt recycling is reliant upon sources of RA. Chapter 5 explores the availability of RA in South Africa, and the distribution of different mix types. It also discusses the influence which other factors have on its quality with respect to its use in hot mixed asphalt.
- It is vital to establish the quantity and quality of RA that can be obtained from a particular project. The asphalt mix type that is to be reclaimed, as well as the properties of its binder, has to be considered. Sampling of the existing asphalt has to be carried out so as to represent as closely as possible the product that will be produced during full-scale operations. These aspects are covered in Chapter 6.
- Chapter 7 provides information on reclaiming asphalt, as well as preparation and stockpiling techniques.
- Once the RA has been prepared and stockpiled it is sampled and the laboratory mix design is carried out. This process is covered in Chapter 8.
- The percentage of RA that can be used in an asphalt mix is dependent to a large extent on the design of the mixing plant. Chapter 9 focuses on the different types of mixing plants available, and gives guidelines regarding their capabilities to handle recycled mixes with different RA contents.
- Chapter 10 discusses measures that are necessary to ensure the quality of hot mix recycled asphalt.
- Several economic factors drive the use of hot mix recycled asphalt. These are covered in Chapter 11.
- Finally Chapter 12 covers health, safety and environmental considerations concerning the producing and use of hot mix recycled asphalt.

Case studies of recent projects where hot mix asphalt recycling has been carried out, are included in the appendix to this document.

3 ASPHALT RECYCLING PROCESSES

Recycling processes that utilise reclaimed asphalt include:

- Cold in-place recycling. The road pavement is recycled in-place using specialised equipment. Bitumen, in the form of bitumen emulsion or foamed bitumen, is added in predetermined quantities during the recycling process. The recycled layer is then shaped and compacted as a layer in the upper part of the pavement and overlaid with a new bituminous wearing course.
- Cold in-plant recycling. In this process the RA is transported to a specialised cold mixing plant where it is mixed together with bitumen emulsion or foamed bitumen in a continuous mixing operation. The cold bituminous mix is paved, or spread with a motor grader, shaped and compacted. The recycled layer is then surfaced with a new bituminous wearing course.
- Hot in-place recycling. The asphalt surfacing layer in the existing pavement is heated in-place using specially designed radiant heaters. The heated asphalt is scarified, lifted into a continuous mix pugmill and mixed together with new aggregate and bitumen or rejuvenating agents. The mixture is then paved and compacted in the same way as conventional asphalt. This process is not currently being used in South Africa.
- Hot mix asphalt recycling is the process in which reclaimed asphalt (RA) is combined with new aggregate and new binder in a mixing plant to produce a recycled mix which satisfies standard specifications for hot mixed asphalt.

3.1 Principles of hot mix asphalt recycling

This manual, which supersedes TRH 21: 1996, covers the last of the processes described above, hot mix asphalt recycling, employing the latest technology developed in this country as well as that currently used in other countries.

The process of hot mix asphalt recycling essentially includes:

- reclaiming asphalt (RA), usually from the asphalt layers of existing pavements, by means of milling machines, but also slabs excavated from asphalt pavement layers, as well as the reuse of returns and tailings at asphalt mixing plants.
- transporting the RA to the mixing plant site.
- preparing and stockpiling the RA.
- mixing the RA in prescribed proportions with new aggregates and bitumen in an asphalt mixing plant.
- transporting the hot mix recycled asphalt to site where it is paved.

Hot mix asphalt recycling is carried out using the two basic types of mixing plants, batch and continuous drum type mixing plants. The design of mixing plants used for recycling is covered in more detail later in this manual, but in essence the plants should be capable of:

- processing the required proportion of RA to meet the end product mix properties.
- conforming to environmental regulations with regard to emissions.
- operating at acceptable production levels.

- switching easily from recycling to conventional asphalt mix production and vice versa.

An important aspect of hot mix asphalt recycling concerns the proportion of RA that is added to the mix. Factors that should be taken into account when decisions are made around the percentage of RA that is to be added to the mix include the:

- type and configuration of the mixing plant.
- type of asphalt mix that is to be produced, for instance continuously graded mixes or SMA.
- moisture content of the RA.
- number of stockpiles and grading of the fractions into which the RA is divided.
- quality of the RA i.e. binder content and properties.
- the layer in which the mix is to be used i.e. wearing course, base, sub-base.
- uniformity and consistency of the RA material.
- possibility that the RA is contaminated with coal tar.

The basic steps that make up the hot mixed asphalt process are depicted in Figure 3.1.

Figure 3.1 The hot-mix recycling process

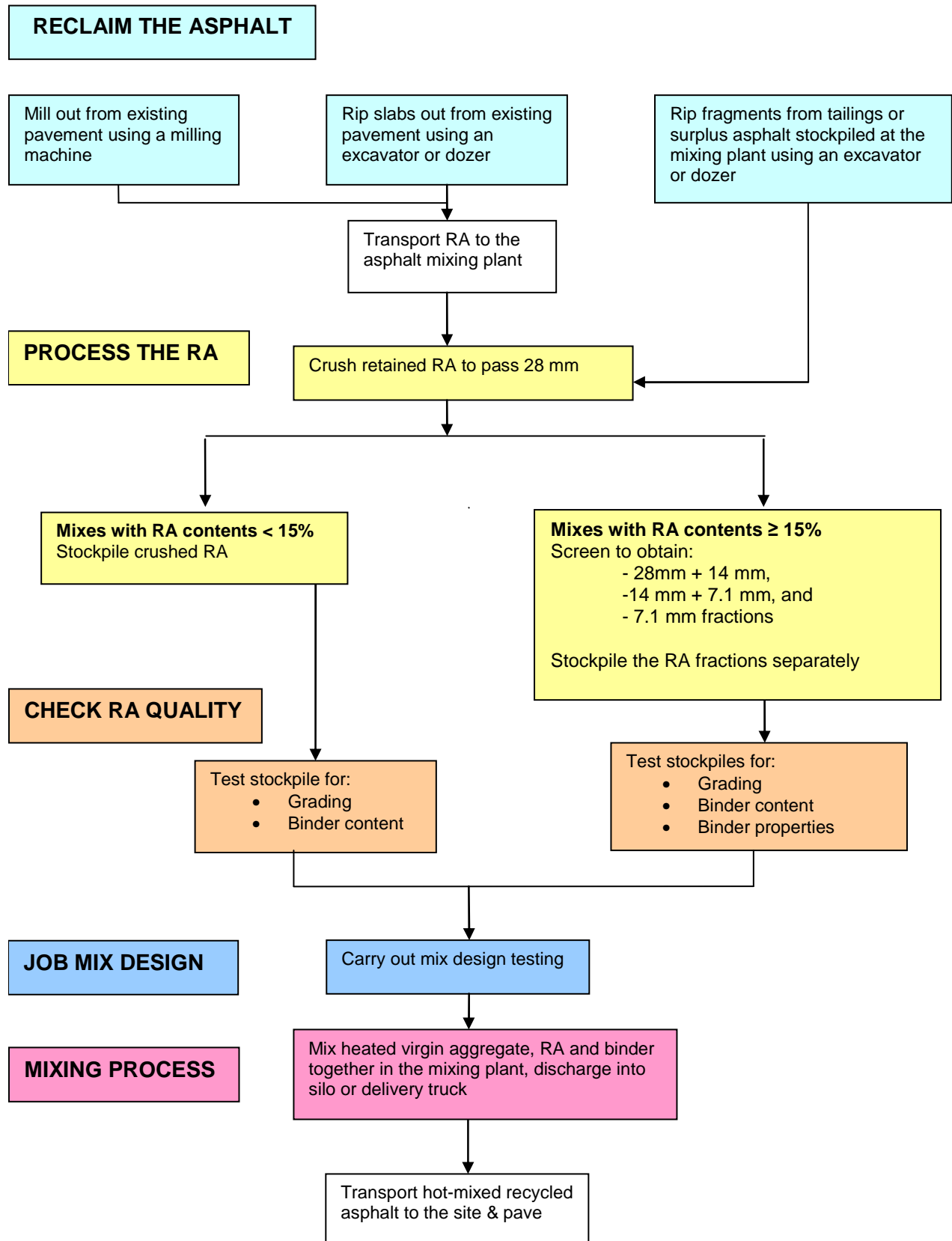

4 CHALLENGES AND SOLUTIONS TO HOT MIX ASPHALT RECYCLING

In PIARC's "*Review of the growth and development of recycling in pavement construction*"¹², three factors are considered to be the main inhibitors to the use of recycling:

- lack of education within the industry regarding the benefits of recycling
- lack of legislation to promote and increase the use of recycling in road construction economy and supply/demand.
-

In the case of hot mix asphalt recycling the potential benefits of using the reclaimed asphalt to produce recycled mixes are often not taken advantage of by road authorities. Due to the misconception that recycled asphalt mixes are of a lower quality than mixes using virgin materials, there is a feeling that a new set of standards is necessary for recycled asphalt mixes to control the end product quality, which they consider would tend to be lower than that of asphalt containing all new materials. This, in fact, is not the case; the same quality standards apply to recycled hot mixed asphalt as for new mix and there is therefore no need to compile new standards.

Client education and legislation to promote the use for recycling tends to be interrelated. Once road and municipal authorities fully appreciate the benefits of recycling they stand in a good position to influence legislators in this regard. There is no doubt that legislation that strongly promotes recycling would have a positive effect in gaining acceptance of the hot mix asphalt recycling process.

As the cost of new aggregate and bitumen increases, the economic advantages of hot mix asphalt recycling also increase. National specifications that allow and even encourage the use of RA in asphalt mixes accrue benefits for the whole industry, with the cost of the main components; aggregates and bitumen, being reduced, together with the added benefit of saving scarce raw materials.

A factor that can influence the use of asphalt that is reclaimed from a particular project is the question of ownership of the RA.

In some cases Road Authorities take ownership of the reclaimed asphalt and are therefore in a favourable position to utilise it in asphalt mixes under their jurisdiction. Provided these Road Authorities make provision in their specifications for recycled hot-mixed asphalt to be used on their projects, the RA can be effectively utilised in this way.

On the other hand a Road Authority may specify that the reclaimed asphalt produced on their projects is owned by the Contractor. The responsibility then rests with the Contractor as how best to utilise the RA. In most cases it will be found that it is financially viable to utilise the RA in their asphalt mixes. Again, as in the previous case, it is necessary for the Road Authority to allow, and even encourage, the use of RA in their asphalt mixes.

5 FACTORS THAT INFLUENCE AVAILABILITY AND QUALITY OF RA

With RA being the essential component in recycled asphalt mixes, factors that influence its availability and quality need to be taken into account.

5.1 Geographical distribution of asphalt pavements in RSA

The feasibility of hot mix asphalt recycling is closely related to availability of RA that can be obtained from the asphalt layers found in road pavements. Obviously the close proximity of asphalt pavements that are able to yield RA impacts positively on the economics of hot mix asphalt recycling, and vice versa.

In large areas of South Africa, where the roads carry low to moderate volumes of traffic, the pavements consist of granular bases with thin surfacing seals, with asphalt only being used on the bridge decks. In fact South Africa is renowned for its successful use of thin surfacings on highly engineered crushed stone bases, and the use of this type of pavement is widespread, particularly in the inland provinces.

Pavements that include at least one asphalt layer are largely confined to the busier provincial roads, certain sections of the national routes, as well as streets in the larger towns and cities. GIS asset registers provide a convenient means of roughly estimating the quantities of asphalt in existing road networks.

Whilst RA is 100% recyclable the restricting factor for using RA in the manufacture of HMA could be the limited availability of sufficient quantities of this material to suit a particular project at the required time. One way to overcome this problem is to ensure that no RA is wasted, but rather stockpiled, even though there may not be a project immediately available where it can be utilised in producing recycled asphalt mixes. The stockpiled RA can then be earmarked for use on future projects. This strategy is especially applicable in metropolitan areas where thick asphalt pavements are more prevalent and there are opportunities to rehabilitate roads within the road network using hot mixed asphalt.

5.2 Current distribution of mix design types

During the past fifty years there have been several changes in the asphalt mixes used in South Africa's road pavements. It is likely that most of the asphalt first used in South Africa consisted of continuously graded mixes. This mix type was largely superseded in the 60's and early 70's by gap-graded asphalt mixes, containing a high proportion of sand, based on British BS 594 standards. These mixes, in which the natural sand fraction had fairly stringent quality requirements, tended to be more durable and less permeable than the continuously graded mixes.

Over the years, as traffic loadings on the country's roads increased, pavements with gap-graded asphalt mixes tended to rut. Semi gap-graded mixes, where the asphalt was more continuously graded, came into use in the late 70's, and were popular for about ten years until they too gave rutting problems. This, and a shortage of natural sand that met the requirements for these mixes, motivated a shift back to continuously graded mixes in the early 90's.

Around this time various modified asphalt mixes, including those containing bitumen rubber, as well as polymers such as SBR and later SBS, were used fairly regularly around the country. Sometimes the gradings of the mixes, particularly those containing bitumen-rubber, were altered to make them more open graded, so that the binder contents of the mix could be increased.

The mid 90's saw the introduction of stone mastic asphalt mixes into South Africa. This mix type, which offers high resistance to rutting and good skid resistance, is gaining in popularity as a wearing course on major roads.

A specialised asphalt surfacing mix that first came into use on South Africa's roads in 1999 is known as Ultra Thin Friction Course (UTFC). This thin (typically 18 mm to 25 mm); functional wearing course has superior riding quality and skid resistance properties.

The various compositions of these different asphalt mix types obviously influence the gradings, binder contents and properties of RA that is reclaimed from South Africa's roads, and must be taken into account when designing recycled asphalt mixes.

5.3 Other factors concerning RA quality

It has been common practice, and certainly this was the case before the introduction of UTFC, to carry out a surfacing seal on top of the asphalt wearing course, as a maintenance measure. Modified binders, such as SBS, and occasionally bitumen rubber, were quite often used in these seals. This makes it likely that many asphalt pavements will be found to contain at least one layer of surface treatment, with the binder possibly consisting of modified bitumen.

Coal tar is no longer used in place of bitumen in South Africa, however PVC modified tar was regularly used in surfacing seals around KwaZulu Natal until the early 90's. A few short sections of asphalt manufactured using coal tar were paved during the late '60s.

The use of tar can usually be detected by its pungent smell, and its incorporation in RA that is destined for hot asphalt recycling is strictly prohibited due to its carcinogenic nature.

Geosynthetic grids or cloths are occasionally used in specific circumstances to retard crack propagation and improve the stability of pavements with asphalt layers. These materials may be found at the bottom of the asphalt layer or sandwiched between asphalt layers. Problems may occur with these materials hindering milling operations, or with pieces contaminating RA stockpiles. The severity of the problems depends on factors such as the position of the geosynthetic material in the asphalt layers, as well as the type of geosynthetic material used.

When these materials are located during the investigation stage it is worthwhile carrying out a milling trial as this will indicate the severity of the problem so that a solution can be found. It should be possible to screen out most of the geosynthetic fragments during the process of fractionating the RA.

Over the many years that asphalt has been used in South Africa, the coarse aggregates have generally been of a high standard, and problems caused by the intrinsic quality of crushed stone fractions in the mix are rare. There is however, some evidence that aggregates manufactured from basic igneous rock types, such as dolerite and basalt, can be prone to degradation over time. This has been known to occur in very isolated instances in the Free State Province, as well as in the Kingdom of Lesoto. When RA contains aggregates derived from basic igneous rock, especially if there is some history of this problem in the area, testing of the intrinsic quality of the aggregates in the RA should be carried out, using tests such as the Soaked Glycol Test.

In very isolated cases poor quality natural sands were used, and cognisance of this should be taken when considering the use of RA from old pavements, where gap-graded asphalt mixes were used.

Stripping of the binder from the aggregate, caused by the poor adhesion properties of the aggregate, is not often encountered, but it is worthwhile to factor this into the checklist when assessing the pavement during the investigation stage, especially in the wet regions of the country. In cases where an asphalt layer is surfaced with an impermeable seal, such as bitumen rubber, the potential for the binder to strip from the aggregate can be aggravated by the "pressure cooking" effect of the seal. As this would affect the quality of the RA any signs of stripping should be noted.

RA from asphalt mixes modified with polymers such as EVA and SBS does not usually present a problem for recycling. Additional care at the preliminary mix design stage should however be exercised when RA from polymer modified asphalt mixes is used in recycled mixes with RA contents in excess of 30%. RA derived from bitumen rubber modified asphalt should be treated with extra caution when the RA content exceeds 15%.

6 INVESTIGATION OF RA SOURCES

6.1 Desk study

When a project is earmarked for rehabilitation, and it is intended to remove the asphalt layers in the existing pavement, there is potential to reuse the old asphalt in recycled asphalt mixes.

Investigations should be tailored around determining the:

- potential quantity of asphalt available.
- haulage distance to the nearest asphalt mixing plant with recycling capability.
- alternatively locating a suitable area for stockpiling the RA ready for future recycling on other projects.
- basic asphalt mix types in the existing pavement.
- uniformity of the asphalt in the existing pavement layers.
- visual condition of the pavement.

The process should start with a desk study of all available historical design and as-built data that could provide information on the specified and constructed thickness of the asphalt layer/s. Descriptions of the mix type/s, such as “continuously graded” or “semi-gap graded” would be useful, as would the penetration grade of the bitumen used, and typical aggregate gradings. In some cases the use of modifying agents may have been recorded, and these details should be noted.

The distance that the RA would have to be transported to the nearest asphalt mixing plant should be ascertained, as this will impact on the economics of the project. Ideally the RA should be transported to the mixing plant in the same tippers delivering the new HMA to site to reduce transport costs.

In some situations where the rehabilitation of more than one project has to be considered, such as in a city environment when the rehabilitation of the road network is being programmed, careful planning of the projects, with respect to their respective locations, as well as sites where RA can be stockpiled, is necessary. Cognisance should be taken of the fact that pavements of city streets are quite likely to include layers of asphalt, which can be effectively utilised in hot recycled asphalt mixes.

Factors that may limit the use of RA include:

- extremely variable mix, where the existing asphalt mix varies over short distances such as severely distressed roads with frequent patches
- asphalt that is contaminated with diesel or oil
- modified asphalt, particularly asphalt modified with bitumen rubber
- areas where the asphalt has a very high binder content
- asphalt contaminated with tar – its use is prohibited for environmental and health reasons

Except for the presence of tar in the RA, these limiting factors can usually be overcome by increasing the number of fractions into which the RA is screened, so as to improve control at the mixing plant. Modified asphalt mixes, especially bitumen rubber modified asphalt, may limit the percentage of RA that can be added to the recycled mix.

6.2 Field investigations

The potential quantity of asphalt that would be available as RA will depend on the extent and depth to which the asphalt is to be removed, as required in the rehabilitation design. Usually, unless the as-built data is available and is in great detail, it is necessary to check quantities by taking core samples and measuring the width of the pavement.

Core sampling should be carried out at intervals of roughly 200m per traffic lane.

The cores should be carefully examined to check:

- the thickness of each asphalt layer found in the core.
- asphalt mix types in each of the layers. The core may show the asphalt to consist of more than one mix type, for instance a layer of gap-graded asphalt with a layer of continuously graded asphalt on top.
- the presence of surfacing seals, particularly those containing highly modified binders for pungent odours, that could denote the presence of tar.
- the presence of geosynthetic interlayers.
- for signs of stripping of the binder from the aggregate.

The need for these examinations to be carried out by experienced personnel is emphasised.

Where sharp variations are found in layer thickness and asphalt mix types, it is worthwhile to take intermediate cores.

Once the cores have been measured and visually examined, samples should be selected for further testing, the complexity of which depends on the percentage and grading of the RA that it is intended to use in the recycled mix.

When RA is fractionated, the binder content of the finer fractions will be significantly higher than that of the coarser fractions.

The use of finer graded RA fractions will therefore tend to influence the binder properties of the recycled mix to a greater extent than the coarser fractions. Thus, if it is decided to use only a finely graded fraction in the recycled mix, it is necessary to carry out Penetration, Softening Point and Viscosity tests with RA contents once more than 10% RA is added to the mix.

When coarser fractions of RA are to be included in the mix, it is not normally only necessary to take binder properties into account if the recycled mix contains more than 15% RA.

In cases where more than one asphalt layer is found in the pavement, or where there are complications due to the presence of modified seals, the results of the core investigation will assist in deciding on the most appropriate milling strategy. For instance it can be decided whether to mill the asphalt layers separately, or to mill more than one layer together, in which case the RA from the two layers will be blended together.

While it is not usually necessary to carry out a detailed visual inspection of the pavement as part of this particular assessment, a more cursory visual inspection should be carried out to determine:

- general types and severity of pavement distress.

- frequency and type of patching.
- any signs of poor performance that could be related to aggregate/binder adhesion problems.

The outcome of this inspection will assist in deciding whether additional core sampling is required.

It should be noted that:

- A broad approach should be taken when considering the utilisation of RA from a particular project. It may not be feasible to use all the RA recovered from a particular project in the rehabilitation of the same project, but other projects where the RA can be used in the asphalt mix should be borne in mind. RA can thus be stockpiled awaiting its use in these projects.
- As discussed in more detail later in this document, RA is stockpiled and processed before it is incorporated in recycled asphalt mixes. This entails thorough mixing during which variations in quality tend to be smoothed out. Thus only significant variations and serious quality problems would result in eliminating the use of RA from a particular source.
- RA sources should not be discarded due to the low penetration grading of recovered binder; instead it should be considered as “black aggregate” and used accordingly. However it should be noted that once an RA content of 20% or more is used in the mix, it becomes necessary to check the material’s recovered binder properties.
- Asphalt that inevitably accumulates at asphalt plants, including tailings and returns, should be considered for use in recycled mixes.

On projects where it is decided to carry out a preliminary mix design, a small milling machine should be used to take samples of the RA, with the number of sampling positions as well as the milling depth based on the strategy developed from a study of the core samples.

7 RECLAIMING, PREPARING & STOCKPILING RA

7.1 Milling RA

Most RA in South Africa is obtained through the use of milling machines rather than by breaking out the asphalt in existing layers in the pavement using excavators or bulldozers and then transporting this material to the crushing plant. An exception to the usual milling method would be the reuse of discarded or surplus asphalt that has been stockpiled at the asphalt mixing plant site.

The main advantages of using milling machines in comparison to the ripping and crushing operation are that they:

- fragment the asphalt to achieve a fairly uniform grading.
- are able to remove the asphalt without disturbing the edges or underlying materials in the pavement.
- are able to remove the asphalt precisely to the prescribed thickness. This enables selective milling to be carried out where this is found desirable during the design stage, such as when more than one type of asphalt is found in the pavement.
- greatly reduce the risk of contaminating the RA with material from the underlying layerworks.

As RA is generally processed by crushing and screening before it is used in the recycled asphalt mix, there are no special restrictions on the milling process itself, such as milling speed, or milling drum and cutting tool configuration. Practical limitations regarding the milling process should however be taken into account, such as the likelihood of contaminating the RA with the underlying granular base when attempting to mill off asphalt surfacing with a thickness of less than 30 mm. An end-product specification, limiting the maximum size of the milled material to 37.5 mm, is advisable.

It has been found that problems can be anticipated when bitumen rubber “SAM” or “SAMI” layers are milled together with the asphalt layer rather than being selectively milled off and discarded. The bitumen rubber seal tends to remain in large, resilient fragments which hinder the crushing and screening processes. Selective milling is therefore recommended when this material is encountered.

7.2 Stockpiling RA

7.2.1 Moisture in RA

An important issue concerning the asphalt recycling process is to limit and if possible reduce the moisture content of the RA before it is recycled. High moisture contents in the RA will result in a decrease in the rate of production and an increase in fuel energy costs, while the increased emissions and steam will tax the mixing plant’s emission control systems. A one percent change in moisture content typically results in a ten percent change in the fuel consumption required to heat the RA.

High moisture contents in RA could also result in high moisture being present in the final recycled asphalt mix, which may lead to adhesion problems.

7.2.2 Stockpiling techniques

It should be remembered that RA tends to retain moisture to a greater extent than aggregate and the following factors should be considered when stockpiling RA:

- the stockpile areas should be sloped (six degree slopes are ideal) so that they drain freely and ponding does not take place.
- the base of the stockpile area should be hardened so that water does not soak into the material under the stockpile. The hardening of the base will also reduce the chance of groundwater contamination and reduce loss of RA through contamination with the underlying soil.
- wherever possible RA should be stockpiled in large conical stockpiles with steep sides. A crust will form on the surface of the stockpile, which will tend to shed water and help reduce consolidation of the rest of the stockpile.
- keep machines off stockpiles to avoid compaction of the RA.
- covering RA stockpiles with tarpaulins or plastic sheets tends to cause condensation which increases its moisture content, and should be avoided. An exception to this is when rain is imminent and the stockpiles can be temporarily covered to prevent the material getting wet. However, as soon as the rain has passed, the stockpiles should be uncovered again to reduce the effect of condensation moistening the RA.
- the best method is to stockpile RA in an open sided shed, which will allow moisture to escape while protecting the material from rain.
- the inevitable variability in grading (and hence binder content) that segregation causes when granular materials are stockpiled is reduced by fractionating the material into fairly similar sized particles.

7.2.3 Processing RA prior to recycling: crushing, screening and fractionating RA

The processing of RA includes crushing, screening, and placing it in separate stockpiles. The aim is to produce a free-flowing material of uniform quality with a defined range of particle sizes in each stockpile. A general rule is that the need to implement these processes becomes increasingly important as the RA content of the recycled mixes is increased. Key factors governing the production of good quality recycled asphalt mixes include consistency and knowing the properties of the stone and bitumen in the RA.

It is generally desirable to fractionate all RA destined for use in hot mix recycled asphalt to enhance the level of control at the mixing plant. However, in the case of low RA content asphalt mixes, containing up to 15% RA, it is usually only essential to remove oversize lumps by passing the RA over a scalping screen.

If the RA is not fractionated, and an RA content close to the top of this limit is required, consideration should be given to installing a roller crusher between the cold feed bin and the transfer conveyor.

An air cannon and off-centre vibratory feeder installed on the RA cold feed hopper will assist in

preventing consolidation of the RA and lumps forming prior to mixing.

When mixes are produced with RA contents above 15%, it becomes necessary to fractionate and screen the RA into separate fractions to ensure a consistent product that will not impair the quality of the asphalt mix.

It is usual to crush the top sieve size of the aggregate in the RA to one size smaller than that of the top size of the aggregate used in a particular mix.

The benefit of installing a crushing and screening system is that small quantities of RA can be processed to produce a consistent material that can be used straightaway, without the risk of it becoming wet from rain water. Ideally sufficient RA should be processed to meet the daily needs for the production of HMA thereby reducing the effect of the RA consolidating during stockpiling. Two types of crushing plants are in general use, horizontal impact crushers and jaw/roller combination crushers.

Typical RA fractions that would enhance the control of the grading, bitumen content and volumetric properties of recycled mixes are shown in Table 7.1. It should be noted that the sieve sizes specified in the SANS 3001 test methods are used in this table.

Table 7.1 Typical RA fractions and uses in recycled asphalt mixes

| Grading of the fractionated RA | Typical usage in recycled asphalt mixes |
|--------------------------------|---|
| - 28 mm + 14 mm | Asphalt base mixes |
| - 14 mm + 7.1 mm | Asphalt base, coarse & medium continuously graded mixes |
| - 7.1 mm | All above, plus fine continuously graded mixes |

As noted previously, the bitumen content of the RA in these fractions varies considerably, with high bitumen contents (typically over 6%) in the minus 7.1 mm fraction and much lower (around 3% bitumen) in the 28 mm to 14 mm fractions.

The grading and binder content of the fractionated RA should be checked at intervals of not greater than 200 tons.

Another factor that should be borne in mind when processing and stockpiling RA from a specific site is to keep it in separate stockpiles, as its characteristics are likely to be similar. Large quantities of RA from different sources should be kept separately for the same reason.

It should be noted that the minus 28 mm plus 14 mm fraction contains aggregations that break up during the heating and mixing process, causing larger fluctuations in the gradings and binder content than the finer fractions. Crushing the RA to pass the 14 mm sieve size is of significant benefit in reducing this variability.

The RA should be handled in three distinct stockpiling phases, as illustrated in Figure 7.1.

Figure 7.1 Phased approach to stockpiling RA

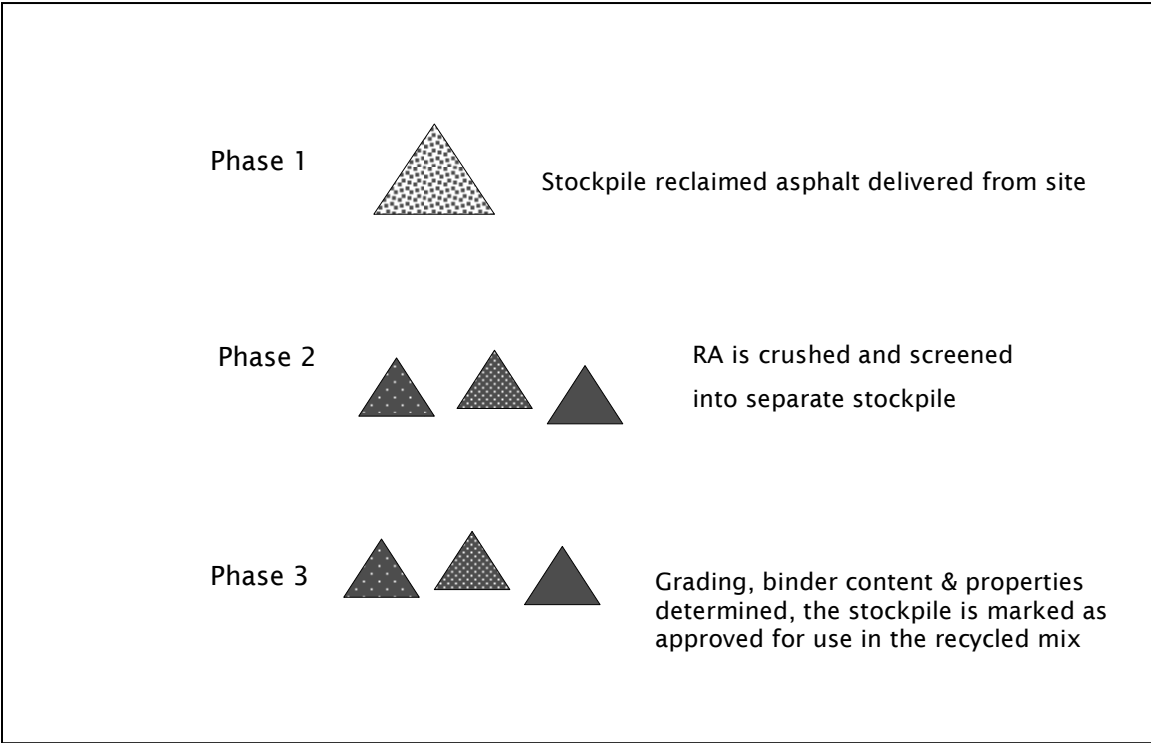

8 MIX DESIGN PROCEDURE

The aim of the mix design is to determine the proportions of new aggregate and RA, as well as the binder content that will fulfil the requirements of the specification. The RA content to be introduced should be determined by mix design characteristics, not by an asphalt plant's capability or by a road authority that wishes to make use of all the milled material available on a specific contract. Although a predetermined proportion of RA should not be specified, it may be advisable to specify a maximum percentage or both maximum and minimum percentages in certain instances. The minimum percentage of RA will ensure that meaningful recycling will occur, whilst the maximum percentage will ensure that quality is not compromised.

Guidelines on the properties of binder that should be added to recycled mixes, depending upon the RA content of the mix, as well as tests required on the aggregate recovered from the RA, are presented in Table 8.1. It should be noted that the properties of the binder in the RA can have a significant influence on the final binder properties in the recycled mix, and these guidelines should be regarded only as a starting point in the mix design process.

Table 8.1 Guideline for binder grade and tests on quality of the aggregate in the RA

| RA content in mix | Additional binder grades | RA Aggregate quality |
|-------------------|--|---|
| < 15% | No change in binder grade | Check intrinsic aggregate properties |
| > 15% | Determine recovered binder properties of the RA. Use blending chart to decide on appropriate binder grade or if rejuvenator agent required | Check coarse aggregate for strength (ACV, 10% FACT), check fine aggregate quality (sand equivalent) |

As mentioned in Chapter 5, the intrinsic properties of the aggregate in the RA should be checked, especially if they consist of basic igneous rock types, such as dolerite or basalt.

Binder recovery should be carried out using either the Abson Method (ASTM D1856) or the Rotary Evaporator (DIN 1996) test method.

8.1 Preliminary Mix Design

8.1.1 Guidelines to establish whether there is a need to carry out a preliminary mix design

On some projects it may be necessary to carry out a preliminary mix design during the investigation and design stage, before full-scale construction work commences.

Reasons for this include:

- the decision to use a high proportion of RA (>30%) in the mix.
- evidence of unusual asphalt mixes in the core samples, such as highly modified mixes, bitumen rubber.
- evidence of surfacing seals with modified binders in the cores.

In summary, preliminary mix designs should be considered necessary whenever there is a need to check the feasibility of recycling the asphalt due to the intrinsic quality of the RA. The layer in which the recycled asphalt is to be used (base or surfacing layer) will also have an impact on the need to conduct a preliminary mix design.

8.1.2 Sampling of asphalt for the preliminary mix design

When a preliminary mix design is required, representative samples of RA should be taken using a milling machine. A small milling machine should preferably be used for this purpose for economic reasons. This will closely simulate the full-scale process of reclaiming the asphalt. The milling should be carried out in accordance with the milling strategy covered in Chapter 6; the milling depth should be set so that the existing asphalt is milled to the required depth. At least 100 kg of RA should be sufficient for the laboratory mix design work. Where the type and quality of the asphalt, as found in the core samples, varies significantly along the project, further samples should be taken and evaluated to determine their influence on the recycled mix.

8.1.3 Preparation of the RA sample

The preparation of the RA before commencing with the mix design depends on the proportion of RA that is intended to be added to the mix. When it is intended to add more than 15% of RA to the mix, the RA should be fractionated as shown in Table 8.2.

Table 8.2 Preparation and testing of the RA before carrying out the preliminary mix design

| Proposed RA content in mix | Preparation of RA | Required tests on RA |
|-----------------------------------|--|---|
| < 15% | Scalp on the 28 mm sieve. Lightly crush lumps to pass this sieve size | Determine binder content and grading |
| 15% to 30% | Scalp on the 28 mm sieve. Lightly crush lumps to pass this sieve size. Fractionate the RA into 3 sizes: 28 mm to 14 mm, 14 mm to 7.1 mm, minus 7.1 mm | Determine binder content and grading of each fraction of RA |
| 30% to 50% | Scalp on the 28 mm sieve. Lightly crush lumps to pass this sieve size. Fractionate the RA into 3 sizes: 28 mm to 14 mm, 14 mm to 7.1 mm, minus 7.1 mm | Determine binder content and grading. Determine recovered binder properties of each fraction of the RA. |

Proportioning of the various sizes of aggregate and filler should be carried out in the same way as for mixes containing all new aggregates, using the results of the grading tests carried out on the RA. In the case of mixes with RA contents higher than 15%, where the RA has been fractionated, blends should be carried out to find the most effective blend that can be used to produce the required grading of the intended mix.

Briquettes used to carry out Marshall tests, as well as other specialised tests should be manufactured using the method specified in SANS 3001-AS1:2009.

In broad outline, this test method includes the following steps relevant to mixes containing RA:

- The new aggregate and RA is dried in an oven at a temperature of between 105°C and 110°C to a constant mass, preferably overnight.
- The required number of portions of each fraction of new aggregate and RA are heated in an oven to 25°C above the required target mixing temperature.
- An appropriate mixing temperature is selected from a table, using the penetration that is achieved by blending the aged binder in the RA with the new binder. An example of a binder blending chart that can be used as a rough guideline is given in Table 8.3.

Table 8.3 Typical binder blending chart

| Typical Blending Chart | | | | | | | | | | | |
|---|------------------------------|--------|--------|--------|--------|--------|--------|--------|--------|--------|--------|
| % of RA | Pen of Recycled Asphalt (RA) | | | | | | | | | | |
| | 5 pen | 10 pen | 15 pen | 20 pen | 25 pen | 30 pen | 35 pen | 40 pen | 45 pen | 50 pen | 55 pen |
| 30.00% | 30 | 37 | 42 | 46 | 49 | 52 | 54 | 56 | 58 | 60 | 62 |
| 25.00% | 34 | 41 | 45 | 48 | 51 | 54 | 56 | 58 | 59 | 61 | 62 |
| 20.00% | 39 | 45 | 48 | 51 | 54 | 56 | 57 | 59 | 60 | 62 | 63 |
| 15.00% | 44 | 49 | 52 | 54 | 56 | 58 | 59 | 60 | 62 | 62 | 63 |
| 10.00% | 50 | 54 | 56 | 58 | 59 | 60 | 61 | 62 | 63 | 63 | 64 |
| 5.00% | 57 | 59 | 60 | 61 | 62 | 63 | 63 | 63 | 64 | 64 | 64 |
| 0.00% | 65 | 65 | 65 | 65 | 65 | 65 | 65 | 65 | 65 | 65 | 65 |
| Resultant Pen of 60/70 Bitumen when mixed with RA | | | | | | | | | | | |

Example: a 60/70 pen grade bitumen blended with 15% RA that has a pen of 20 will have a resultant pen of 54

| Typical Blending Chart | | | | | | | | | | | |
|---|------------------------------|--------|--------|--------|--------|--------|--------|--------|--------|--------|--------|
| % of RA | Pen of Recycled Asphalt (RA) | | | | | | | | | | |
| | 5 pen | 10 pen | 15 pen | 20 pen | 25 pen | 30 pen | 35 pen | 40 pen | 45 pen | 50 pen | 55 pen |
| 30.00% | 23 | 29 | 32 | 35 | 38 | 40 | 42 | 43 | 45 | 46 | 48 |
| 25.00% | 26 | 31 | 34 | 37 | 39 | 41 | 42 | 44 | 45 | 46 | 47 |
| 20.00% | 29 | 33 | 36 | 38 | 40 | 41 | 43 | 44 | 45 | 46 | 47 |
| 15.00% | 32 | 36 | 38 | 40 | 41 | 42 | 43 | 44 | 45 | 46 | 46 |
| 10.00% | 36 | 39 | 40 | 41 | 42 | 43 | 44 | 44 | 45 | 45 | 46 |
| 5.00% | 40 | 42 | 43 | 43 | 44 | 44 | 44 | 45 | 45 | 45 | 45 |
| 0.00% | 45 | 45 | 45 | 45 | 45 | 45 | 45 | 45 | 45 | 45 | 45 |
| Resultant Pen of 40/50 Bitumen when mixed with RA | | | | | | | | | | | |

Example: a 40/50 pen grade bitumen blended with 10% RA that has a pen of 15 will have a resultant pen of 40

| |
|--|
| Assumptions |
| Both the RA and the asphalt have the same % binder. |
| The pen of the bitumen is at the mid point. ie 65 for the 60/70 and 45 for the 40/50 |

- The required percentage of new binder is added to the combined aggregate and RA and mixed thoroughly with a mechanical mixer for the period shown in Table 8.4.

Table 8.4 Laboratory mixing time for mixes containing various proportions of RA

| MIXING TIME (min ± 5 sec) | RA IN MIX (percent) |
|------------------------------|------------------------|
| 5 | < 15% |
| 7 | 15 to 30 |
| 8 | > 30% |

- The appropriate compaction temperature is selected from a table, using the penetration that is achieved by blending the aged binder in the RA with the new binder.
- Place the mixed material in an oven set at the required compaction temperature, cover and cure for a period of 60 minutes.
- Transfer the material to heated Marshall moulds and compact as specified in SANS 3001-AS1.

8.2 Main mix design

Notwithstanding the fact that a preliminary mix design may already have been carried out due to reasons given in Chapter 8.1.1, it is still necessary to carry out a full mix design once the asphalt has been reclaimed and stockpiled. When it is intended to produce low RA content mixes (less than 15% RA), and fractionating has not been carried out, only the one stockpile will need to be sampled.

8.2.1 Sampling procedure

The stockpile should be sampled with the help of a front end loader, following the method described in TMH5 Sampling Method MB1¹⁶.

Binder content and grading tests should be carried out on each of the samples, and the results should be scrutinised for variations in the results. Where large variations are noted, precautions to improve the uniformity of the mix should be taken, such as mixing the material with the front end loader before it is loaded into the cold feed hopper or by increasing the number of fractions into which the RA is screened.

As already stressed in this document, the moisture content of the RA should be kept as low as possible, and moisture content checks should be carried out on the various RA stockpiles as part of the mix design testing programme.

When it is intended to use proportions of RA higher than 15% in the mix, and it is necessary to fractionate the RA, each of the stockpiles should be sampled in the same way. One of the main advantages of fractionating the RA is that a much higher level of uniformity can be expected.

Tests on the recycled mix should include the same tests as would routinely be carried out on asphalt mixes containing all new aggregate, including the usual volumetric and strength tests. The testing programme should include tests to evaluate moisture sensitivity, such as the Immersion Index test.

8.2.2 Mix design testing

The same steps should be taken with the main mix design as for the preliminary design. In the case of mixes with higher RA proportions, where the RA is fractionated, it will be necessary to determine the most effective blends that can be produced using the various RA fractions.

The proportion of RA that can practically be added to a mix will depend on the type of mix that it is intended to produce. For instance, only a small percentage of the minus 7.1 mm fraction can be utilised in stone skeleton type mixes such as SMA.

Table 8.5 gives recommendations for the maximum RA content that can be used in the manufacture of hot mixed asphalt.

Table 8.5 Guidelines for maximum RA contents in various asphalt mix types

| Type of layer or mix | % RA of new HMA |
|---|-------------------------|
| Wearing course: <ul style="list-style-type: none">• SMA• Polymer modified medium graded• Unmodified medium graded | Less than 3 12 18 |
| Binder course | 23 |
| Base course | 27 |

8.2.3 Plant mix trials

Once the mix design has been completed using laboratory mixed samples, trial mixes should be carried out by manufacturing small quantities in the mixing plant at three different binder contents, targeting the optimum binder content found in the laboratory mix, as well as at bitumen contents 0.5% above and below the optimum. The results of tests on these trial mixes should be examined, as there is often some shift between mixes produced in the laboratory compared to those manufactured full-scale, and final adjustments should be made accordingly. The moisture content of the final product should be checked again to ensure that the mix complies with maximum moisture requirements.

9 MIXING PLANT REQUIREMENTS

While the same basic types of mixing plants used to produce conventional hot mix asphalt are used to manufacture recycled asphalt mixes, some changes are required to enable them to produce mixes of the same quality as those using all virgin aggregates. Additionally the mixing plants must be designed to comply with the same gas and particulate emissions standards when producing recycled mixes as they are for conventional asphalt mixes; they should comply with National Environment Management Air Quality Act (Act No 39 of 2004). Guidelines regarding the various types of mixing plants can be found in SABITA Manual 5¹⁵, as well as in NAPA Information Series 123¹⁰.

Asphalt mixing plant design has undergone significant development over the past ten years, particularly in the use of microprocessor systems that automate the cold feed and mixing operations. Two basic types of asphalt mixing plant are available; batch-type and continuous drum mixer type plants. Both types of mixing plant have been adapted to enable RA to be added to the mix, and include systems to facilitate the venting of steam and the proper transfer of heat from the virgin material to the “cold” RA as it is being introduced into the mix.

9.1 Mixing plant types and capabilities

9.1.1 *Batch plants*

With batch type plants two broad options exist to introduce the RA into the asphalt mix:

Option 1 Pugmill recycling using a separate RA weigh hopper

The RA is fed directly into the pugmill via a weigh hopper. The virgin aggregate has to be superheated to accommodate the “cold” RA. A slight adjustment may have to be made to the dry mix cycle to facilitate better heat transfer. Care is required when utilising this option to ensure that the steam that is generated during the first few seconds after the RA is fed into the pugmill, is properly vented into the dust extraction system. A mini explosion occurs as the moisture in the RA makes contact with the superheated aggregate. After this initial burst, the steam is being released relatively slowly (typically within a period of 30 seconds) by the vigorous mixing process in the pugmill.

It is possible to increase the RA contents of mixes using this process if the RA is dried prior to being introduced into the pugmill, and various drying systems exist in order to facilitate this. This system is illustrated in Figure 9.1.

Figure 9.1 Pugmill recycling using a separate weigh hopper

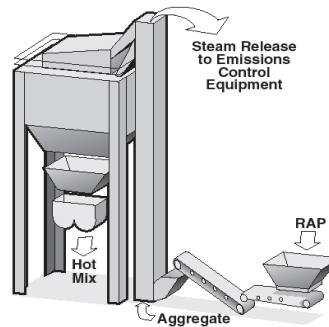

Option 2 Introducing RA into the bucket elevator

RA is fed via a cold feed bin directly into the hot elevator at the point at which the heated virgin aggregate is discharged from the drying drum. The RA material mixes with the hot virgin aggregate in the bucket elevator, releasing steam more gradually as the material is lifted in the elevator to the screening deck. Thereafter the blend of RA and virgin aggregate is weighed off and falls into the pugmill where it is thoroughly mixed together with the binder. This process facilitates good heat transfer from the virgin aggregate to the RA as the RA remains in contact with virgin aggregate for a relatively long period. This eliminates the violent release of steam associated with the direct pugmill heat transfer method. This process is illustrated in Figure 9.2.

Figure 9.2 Introducing the RA into the bucket elevator

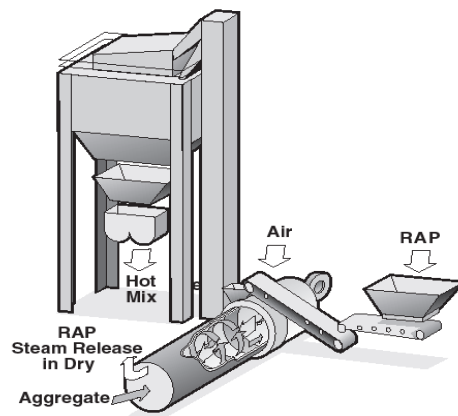

9.1.2 Drum plants

When it comes to continuous drum-type mixing plants, two basic configurations are available, parallel flow and counter flow. Feeding RA into a drum type plant is easier as the generation and venting of steam can be managed more easily through the drum, which has a larger area. However, the possible risk of generating “blue smoke” is greater, as in some instances the burner flame makes direct contact with the RA as it is being fed into the drum.

The most basic parallel flow drum mixer utilises a cold feed bin for the metering of RA and then feeding it into the drum via an inclined belt, in the same way that virgin aggregate is fed into the drier drum. Due to the fact that the flame is in direct contact with the RA material, so-called “blue smoke” may occur, and the proportion of RA that can be used in the mix is therefore limited to a maximum of 10%.

Parallel-flow drum mixers can be equipped with a centre RA ring. This mid-entry design system enables the RA to be kept away from the high temperatures at the burner end of the drum, thus reducing damage to the binder in the RA and reducing “blue smoke” emissions. The percentage of RA that can be used with this type of mixer is still limited by the level of emissions caused by the effect of high temperatures on the binder that is added during the recycling process. A maximum of 25% RA is usually achievable with this type of plant.

The use of a separate rotating mixing drum or continuous pugmill, known as an “after mixer” or “coater”, where the heated mixture of virgin aggregate and RA is mixed together with the binder, reduces emissions, as the hot gasses from the mixing drum do not come into direct contact with the binder and the RA content can consequently be increased to at least 30%.

The design of counter-flow drum mixers, where the burner is located at the opposite end of the drum to that into which the virgin aggregate is fed, enables excessively high process gas

temperatures to be reduced by the cooler, moisture laden aggregate as the gasses evacuate the dryer. Steam is typically exhausted at the burner end of the dryer while hydrocarbons carried in the air stream are destroyed by the high temperatures that prevail in this part of the drum.

Various different types of counter-flow drum mixers exist:

- counter-flow drum with a RA ring. Mixing takes place in the drum on the burner side of the RA ring.
- counter-flow drum with an after-mixer (or coater) where mixing takes place. This type of design is shown in Figure 9.3.

Figure 9.3 Counter-flow drum mixer with separate after-mixer

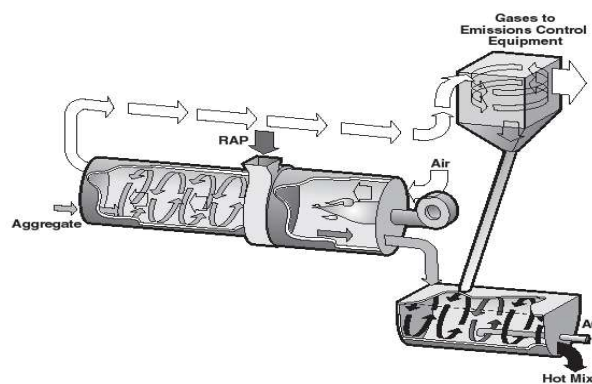

- twin drums, which consist basically of a counter-flow drum where drying and heating of the virgin material takes place, and a second drum (or in certain instances a barrel wrapped around the first drum) where mixing takes place. Typically, the percentage of RA that can be used is substantially higher when double/twin drum mixers are used, and mixes containing up to 70% RA can be produced successfully. The principle of the double-drum mixing system is illustrated in Figure 9.4.

Figure 9.4 Double-drum type mixing plant

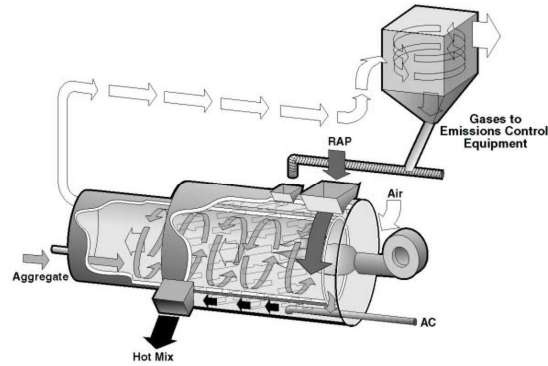

Of primary concern, when any of the various type of mixing plants are used, is that the RA and the virgin aggregates are properly blended together; the blending process facilitates good heat transfer and prevents both mechanical and thermal segregation.

Table 6 shows the maximum capabilities of the various types of mixing plants in terms of the percentage RA that they are typically able to handle.

Table 9.1 Typical maximum RA capabilities of different types of mixing plant

| Type of mixing plant | Maximum % RA |
|-------------------------------------|--------------|
| Batch mix | |
| • Pugmill only | 15 |
| • Pugmill and hot elevator | 30 |
| Drum mix | |
| • Parallel flow feed with aggregate | 10 |
| • Parallel flow with centre ring | 20 |
| • Counter flow with RA ring | 20 |
| • Counter flow with after-mixer | 30 |
| Twin dryer drum | 50 |
| Double barrel drum | 70 |

9.2 Cold feed systems

When the RA has been fractionated it is necessary to provide a separate cold feed bin for each fraction. To enable the RA to be added smoothly, without the risk of blockages the following points should be taken into account:

- the sides of the cold feed bins should be built steeper than those used for new aggregates
- lengthen the openings of the cold feed bins onto the feed belts
- longer feed belts are required
- dribble the RA into cold feed bin to prevent packing
- avoid use of vibrators
- do not leave RA with a high binder in the cold feed bins overnight.

The requirements of mixing plants, as well as factors that influence the proportion of RA that can be added to hot recycled mixes are summarised in Table 9.2.

Table 9.2 Mixing plant requirements and factors that influence RA content

| RA Content | RA Preparation | Mixing plant requirements | | Binder adjustments |
|------------------|---|--|--|--|
| | | Cold feed | Mixing | |
| Less than 15% | Fractionating RA is desirable but not essential. Scalp oversize | One cold feed bin is required for the RA if it is not fractionated | Batch plants with separate RA weight hoppers are suitable. Exhaust system modification required for mixes with >10% RA. Parallel-flow and counter-flow drum mixers with RA collars at mid-point of drier drum are suitable | Carry out mix design using normally specified bitumen grade. No change in bitumen grade is normally necessary, but could be changed after reviewing the mix properties |
| 15% to 30% | Crush, screen and fractionate mixes with >20% RA | Cold feed bin required for each RA fraction | Batch plant, with modified exhaust systems, are suitable up to 20% RA. Counter-flow drum mixers with RA collars at mid-point of drier drum are suitable. Parallel-flow drum mixers require separate continuous mixer where the binder is added | Carry out mix design using one grade softer than normally specified bitumen grade. Review binder grade based on the mix properties obtained in the design. |
| Greater than 30% | Crush, screen and fractionate | Cold feed bin required for each RA fraction | Parallel-flow mixers require separate continuous mixer where the binder is added, exhaust system to be modified. Specialised plants, such as double drum or twin drum mixing plants are required when >40% RA is used in the mix | Ascertain properties of binder recovered from the RA. Carry out mix design with bitumen grade based on combined binder properties |

10 QUALITY CONTROL OF HOT MIX RECYCLED ASPHALT

The quality of the hot mix recycled asphalt is monitored in much the same way as asphalt containing all new materials, except for the following addition testing:

- **check the RA stockpiles as they are being replenished for:**
 - Binder content.
 - Grading.
 - Recovered binder properties when RA contents of the recycled mixes exceed 15%.
 - Moisture content.

- **check the quality of the recycled mix for:**
 - Moisture content (maximum 0.5%). The moisture content of the recycled mix should be checked at least once per day - anything in excess of 0.5% may be a problem as this is indicative that the moisture in the RA is not being completely removed via the heating process. Under extreme conditions, RA can be pre-dried through the asphalt plant the day before in order to reduce its moisture content. An unusually large drop in the temperature of the mix between the asphalt plant and the paving site may be indicative of a high moisture content.

 - Moisture susceptibility using tests such as Immersion Index or the modified Lottman test.

11 ECONOMIC CONSIDERATIONS OF HOT MIX RECYCLED ASPHALT

Despite the environmental benefits of recycling asphalt, the main driver for reusing RA in new mixes is that it is economical to do so; the fact that has been established in several countries that the inclusion of RA in hot mix asphalt offers asphalt producers a competitive advantage.

This economic benefit is especially true in view of the recent increases in bitumen and fuel costs which have made producers take a hard look at ways of retaining hot mixed asphalt as a cost-effective road building material.

Hot mix recycled asphalt offers direct savings per ton of hot mixed asphalt produced in terms of reductions in:

- **Lower virgin aggregate consumption** The inclusion of RA reduces the quantity per ton of virgin aggregate required in the asphalt. Provided haulage distances for the RA are not excessive, the cost per ton of RA is lower than that of virgin aggregate.
- **Lower bitumen consumption** For every 10% of RA used in the mix, the bitumen content of the mix can be reduced by roughly 0.5%. With the tendency for the bitumen price to rise over a period of time, the saving in the quantity of bitumen that it is necessary to add to the mix becomes increasingly significant, as illustrated in Figure 10.1.

Figure 10.1 Influence of bitumen price and RA content on HMA price

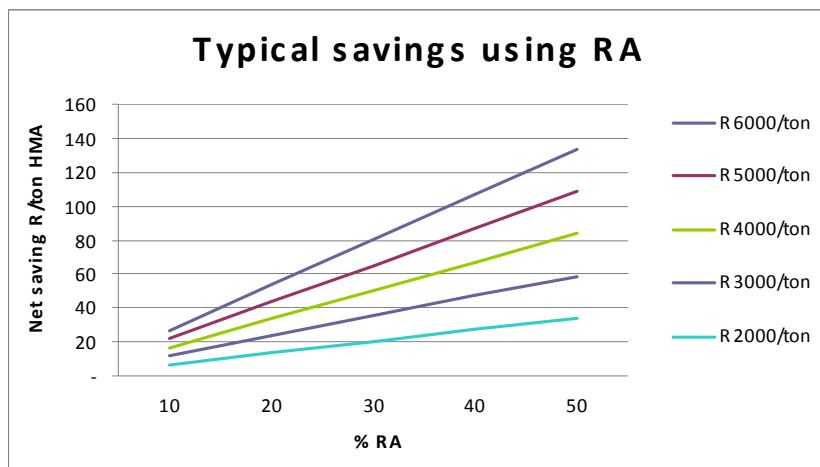

- **Less bitumen required in the asphalt mix**

With the RA providing some of the binder in the recycled hot mixed asphalt, less new bitumen is required to optimise the mix's binder content. This results in less energy being required to heat the bitumen during transport, storage and mixing.

- **Bitumen transport costs**

In the same way, a reduction in the quantity of bitumen in the mix means that less bitumen has to be transported from the refinery to the asphalt mixing plant.

- **Inappropriate use of RA**

RA, which is intrinsically high quality crushed stone with a bituminous coating, is a valuable resource which should not be wasted by inappropriate use, such as its use as a base to upgrade minor unsurfaced roads. The hot mix asphalt recycling process optimises the use of RA in the production of high-value asphalt mixes.

- **Waste disposal to land fill**

Instead of occupying space in landfill sites, the RA is utilised in the manufacture of asphalt that conforms to the normal quality standards applied to hot mixed asphalt using all virgin aggregates. In addition, charges related to the disposal of waste in landfill sites are eliminated by using the RA in hot mixed asphalt. Waste levies, such as the State Waste Levy imposed in Australia, are negated by using the RA in asphalt mixes instead of disposing it in a land fill.

The above cost savings obviously have to be offset against the additional costs incurred in handling and processing of the RA in the hot mix asphalt recycling process.

Key factors come into play when considering the economics of hot mix recycled asphalt, mainly around the proximity of the project to:

- **Sources of RA**

The value of the RA is influenced to a large extent by the distance it has to be transported from the jobsite to the asphalt mixing plant. Long RA haulage distances obviously reduce the direct economic benefits of recycling.

- **Sources of suitable quality crushed stone**

The haulage costs of virgin aggregates influence the economics of the recycled asphalt mixes in the same way.

- **Sources of bitumen**

The economic benefit resulting from the reduction in the quantity of bitumen required to produce recycled asphalt mixes is already covered in this chapter. Long haulage distances from refinery to asphalt mixing plant, which result in higher priced bitumen, increase the economic benefit of recycled asphalt mixes.

- **Static or mobile asphalt plants with the capability to produce hot mix recycled asphalt mixes**

The location of the nearest asphalt mixing plant in relation to the jobsite where the RA is available is an important factor in determining the cost-effectiveness of hot mix recycling.

12 OCCUPATIONAL HEALTH, SAFETY AND THE ENVIRONMENT

Whilst recycling of asphalt has major environmental benefits, care must be taken to ensure that worker safety is not compromised, nor the air polluted during asphalt mixing operations.

Occupational health and safety issues

Care must be taken during the milling, when the aged asphalt is removed from the pavement, to avoid exposure of the workers to the dust that is generated during these operations.

Before milling the necessary steps must be taken to identify if any tar is present in the asphalt layer. As already mentioned in Chapters 5 and 6, coal tar was used in surfacing seals, especially in the Province of Kwazulu Natal, as is known to have been used as the binder in asphalt mixes in a few short sections of road.

Coal tar is known to have carcinogenic properties and RA containing it should therefore be regarded as hazardous. Workers involved in reclaiming materials that contain tar should therefore be equipped with appropriate protective clothing and breathing apparatus, and the reclaimed material should be removed to a registered hazardous waste site.

If there is no tar present in the reclaimed asphalt, it can be considered as being inert and can therefore be handled like virgin aggregate. If tar is present in the RA, it can present a health risk to workers if they are exposed to the fumes during paving of the new recycled asphalt.

During the manufacture of the recycled asphalt, hot bitumen is mixed with heated aggregates at temperatures above 150°C. The main hazards and dangers associated with the handling of hot binders is the risk of workers being burnt if their skin comes into contact with the hot product. All workers involved with the handling of the hot binder must be issued with Personnel Protective Equipment (PPE) and have undergone safety training. Hot binders are handled below their minimum flash point requirement of 230°C and therefore if handled correctly present a low fire risk. For more details refer to SABITA Manual 8 "*Guidelines for the safe and responsible handling of bituminous products*".

In some instances aromatic oils may be used to rejuvenate the aged binder in the reclaimed asphalt. Some of these aromatic oils contain high concentrations of harmful Polycyclic Aromatic Hydrocarbons (PAHs) and every precaution must be taken to reduce the exposure of workers to fumes or skin contact. If aromatic oils are used the manufacturer must refer to the suppliers Material Safety Data Sheet for advice on what precautions should be taken when using these products.

Environmental issues

In the interests of sustainable practice, reclaimed asphalt is a valuable resource as it contains both aggregates and bitumen which are both non-renewable resources. To this end every effort should be made to encourage the recycling of aged asphalt by ensuring that it is utilised optimally in the manufacture of new asphalt.

During the mixing of the asphalt excessive fuming can occur if the reclaimed asphalt is exposed to the burner flame in the drum mixer. This can in turn become a restriction in terms of the percentage of RA that can be recycled and is very much plant dependent. Baghouse emission control systems may not be adequate when high percentages of RA are used and supplementary or other types of emissions control systems may be necessary in these cases.

13 REFERENCES

1. Brock D and Richmond J, *Milling & Recycling*, Technical Paper T-127, Astec 2007, USA.
2. European Standard EN 13108-8, *Bituminous mixtures – materials specifications – Part 8: Reclaimed asphalt*, Brussels 2005.
3. Beukes JT, White M, Onraët JM, *Batch plant recycling for a road rehabilitation contract in the Western Cape*. Proceedings, 5th Conference on Asphalt Pavements for Southern Africa, Swaziland 1989.
4. CSIR Special Report PAD 65, *Hot mix recycling: mix design procedure*. Division of Roads and Transport Technology, CSIR, Pretoria, South Africa, March 1988.
5. CSIR Special Report PAD 70, *Hot mix recycling: plant requirements*. Division of Roads and Transport Technology, CSIR, Pretoria, South Africa, October 1989.
6. CSIR Special Report PAD 72, *Hot mix recycling: contractual procedures and specifications guidelines*. Division of Roads and Transport Technology, CSIR, Pretoria, South Africa, March 1990.
7. *Draft TRH21: 1996 Hot mix recycling*. Technical recommendations for highways. Committee for State Road Authorities. 1996.
8. Jones DER, Loader MG, Lewis AJN, Newell JD, *Quality assurance and construction techniques for hot recycled asphalt with high content of reclaimed materials*. Proceedings, Sixth Conference on Asphalt Pavements for Southern Africa, Cape Town 1994.
9. Newcomb D *et al*, *Designing HMA mixtures with high RAP content - a practical guide*, Quality Improvement Series 124, National Asphalt Pavement Association 2007, USA.
10. Young T, *Processing and handling RAP*, Information Series 123, National Asphalt Pavement Association 2007, USA.
11. Austroads, *Framework specifications for Asphalt Recycling AP-T02*, ARRB 2000.
12. PIARC Technical Committee 4.3 Working Group 2, *Review of the growth and development of recycling in pavement construction*, draft July 2007.
13. TMH1 *Standard methods for testing road construction materials*, Pretoria.
14. Rebbechi J, *Austroads guide and commentary series Appendix 6 Asphalt Recycling*, ARRB 2005.
15. SABITA Manual 5, *Guidelines for the manufacture and construction of hot mix asphalt*, January 2008 4th Edition. ISBN 978-1-874968-31-3.
16. TMH 5, *Sampling methods for road construction materials*.

17. NAPA Information Series 123, *Recycling hot-mix asphalt pavements*, National Asphalt Paving Association 2007.

APPENDIX

CASE STUDY No. 1

REHABILITATION OF NATIONAL ROUTE N3 BETWEEN THE MARIANNHILL TOLL PLAZA AND KEY RIDGE

PROJECT DESCRIPTION

This contract involved the rehabilitation of the 12 km section of National Route 3 between the Mariannhill Toll Plaza and Key Ridge, one of the most heavily loaded pavements in South Africa. Most of the northbound carriageway is at a grade of 3,5% to 5,0%, resulting in heavy vehicles travelling slowly, increasing the time of loading on the pavement. Total truck traffic is in the order of 6 000 per day of which more than half are long distance interlink trucks travelling between the port of Durban and Gauteng. Daily equivalent standard axles (ESAL) are in the order of 9 000 per direction. The predicted total cumulative design loading of the pavement is about 70 million ESAL over 15 years and 150 million over 25 years.

REHABILITATION DESIGN

The existing pavement of this dual carriageway freeway consisted of a total thickness of 160 mm of semi gap-graded asphalt base and surfacing, on top of 300 mm of stabilised subbase. A bitumen rubber surfacing seal had been applied over portions of the section.

The asphalt in the existing slow lane was removed completely due to signs of stripping in the lower parts of the layer. This was replaced with 160 mm of hot-mixed asphalt, paved in two layers of 80 mm each. In the middle lane and on isolated sections of the fast lane, 80 mm was removed and replaced with one layer of hot-mixed asphalt.

The completed asphalt base was surfaced with Ultra Thin Friction Course.

ASPHALT MIX DESIGN

Due to the high tyre pressures and wheel loads, combined with slow moving heavy vehicles, it was important to design an asphalt mix with a high resistance to rutting, without compromising the fatigue properties of the mix.

On this contract the Road Authority specified that the reclaimed asphalt (RA) would become the property of the Contractor. This opened the opportunity to recycle the RA in the asphalt base mix, and the Contractor's proposal to include 10% to 12% of RA in the mix was accepted by the Road Authority.

A preliminary mix design was undertaken using RA reclaimed from the pavement. The Bailey method was used extensively to determine the optimum aggregate packing of the mix and this resulted in a grading that was slightly coarser than the normal COLTO grading envelopes.

In order to enhance the rut resistance and fatigue properties of the asphalt mix, a laboratory assessment was made on mixes made from two types of modified binders, A-P1 (modified with 4% EVA polymer) and A-E2 (modified with 3,5% SBS). The normal Marshall mix design method was carried out to determine the optimum binder content of the two mixes. In addition

to the Marshall design method, gyratory compaction was carried out at the optimum binder content of mixes containing each of the two binders.

TRIAL SECTIONS

In total, six trial sections were constructed with three different binder contents, (below optimum, optimum and above optimum), and extensive testing was carried out which included:

- Hamburg wheel tracking tests
- MMLS tests on cores, wet and dry at two rates of load application
- Flexural beam fatigue test

Based on the results from these tests the mix using 12% RA with A-P1 modified binder was selected as the production mix for this contract

RECLAIMING AND PROCESSING THE RA

The asphalt in the existing pavement was milled out and stockpiled at the asphalt mixing plant site. Where sections surfaced with the bitumen rubber seal was encountered, this was not milled off selectively but was milled together with the underlying asphalt.

The RA was not crushed but was fractionated by passing it through a triple deck screening plant with 25 mm, 16 mm and 8 mm screen sizes.

Typical grading and binder contents of the two fractions of RA used in the recycled asphalt mix are shown in Table 1.

Table 1 Typical grading and binder contents of RA used in the recycled asphalt mix

| Sieve Size (mm) | Percentage passing | |
|---------------------------|--------------------------------|---------------------|
| | Minus 16 mm plus 8 mm fraction | Minus 8 mm fraction |
| 19.0 | 100 | |
| 13.2 | 94 | |
| 9.5 | 80 | 100 |
| 6.7 | 60 | 98 |
| 4.75 | 49 | 91 |
| 2.36 | 38 | 73 |
| 1.18 | 33 | 59 |
| 0.600 | 28 | 49 |
| 0.300 | 20 | 34 |
| 0.150 | 11 | 20 |
| 0.075 | 7 | 12 |
| Binder content (%) | 4.2 | 5.8 |

The RA was screened so as to provide sufficient quantity for approximately three days of recycled asphalt production, with the binder content being checked at daily intervals as the screened RA was being stockpiled.

DETAILS OF THE ASPHALT MIXING PLANT

A continuous parallel flow drum mixing plant with a centre RA feed ring was used to produce the hot-mix recycled asphalt. This plant is equipped with 11 cold feed bins for virgin aggregate as well as 2 cold feed bins to supply RA to the drying/mixing drum. An average mix discharge temperature of 160°C was achieved.

PAVING DETAILS

In total 56 000 tons of the hot-mix recycled asphalt was paved on this contract, with daily paving rates between 400 tons and 600 tons being achieved. As mentioned the mix was paved either in two 80 mm thick layers in the slow lanes or in one 80 mm thick layer in the middle and fast lanes, with compaction being carried out by two 8 ton vibratory rollers and two 22 ton pneumatic tyred rollers. Results of tests carried out during the trials showed that significant improvements in the mix's performance could be expected at high levels of compaction, namely with compaction levels between 94% and 95,5% (based on maximum theoretical relative density). In fact an average 94% density was achieved on this work.

MIX PROPERTIES

Process control during the course of the contract involved the testing of over 400 samples. All the hot-mixed recycled asphalt utilised on this contract was found to comply with the specifications. Average values of the full set of process control results, which include gradings and other properties, are summarised in Table 2.

Table 2 Average values of the full set of process control results of gradings and other properties

| SIEVE SIZE (mm) | Average values | Specification |
|---------------------------------|----------------|---------------|
| 26.5 | 100 | 100 |
| 19.0 | 96 | 85-95 |
| 13.2 | 80 | 71-84 |
| 9.5 | 69 | 62-84 |
| 6.7 | 57 | 53-69 |
| 4.75 | 49 | 42-60 |
| 2.36 | 33 | 30-47 |
| 1.18 | 24 | 21-37 |
| 0.600 | 18 | 15-30 |
| 0.300 | 13 | 11-24 |
| 0.150 | 9 | 8-19 |
| 0.075 | 5.8 | 5-12 |
| Filler/bitumen ratio | 1.4 | 1.0 – 1.5 |
| Bitumen content (%) | 4.1 | 3.9 – 4.5 |
| Film thickness (microns) | 7.0 | 5.5 – 8.0 |
| Binder absorption (%) | 0.2 | 0.5 max |
| Void content (%) | 4.5 | 4.0 – 6.0 |
| VMA (%) | 13.6 | 14.0 min |
| VFB (%) | 66.9 | 65 – 75 |
| Marshall stability (kN) | 16.7 | 8 – 18 |
| Flow (mm) | 3.3 | 2 – 6 |
| Stability/Flow ratio | 5.2 | 2.5 min |
| Indirect tensile strength (kPa) | 1565 | 1000 min |

EXPERIENCE GAINED

This contract illustrated the fact that moderate amounts of RA could be successfully used in the production of modified asphalt mixes for projects that carry extremely heavy traffic loadings.

The following lessons regarding the use of reclaimed asphalt in the manufacture of hot-mix asphalt were learnt during the course of the work:

- Selective milling was not carried out to remove the bitumen rubber seal. During the process of fractionating the RA, flexible pieces of the seal tended to stick together and had to be scalped off, without causing a problem. However, should the RA be crushed prior to screening it is likely that the material from the bitumen rubber seal would jam in the crusher, causing delays. With this in mind, when highly modified surfacing seals are encountered and it is the intention to crush the RA, it would be advisable to firstly mill off the seal before proceeding to mill out the asphalt.
- As mentioned, the RA on this contract was not crushed and the material scalped off on the 25 mm screen was not used in the mix. The installation of a crusher would enable the whole RA product to be crushed and used in the mix, thus reducing wastage.
- When coarser RA fractions, such as the minus 25 mm plus 16 mm fraction, are used, the grading and binder content tends to be more variable than when finer fractions of RA are used in the recycled mix; this is due to the variable quantities of “clods” or agglomerations being formed by finer particles that stick together.

CASE STUDY No. 2

USE OF HOT RECYCLED ASPHALT MIXES AT THE OR TAMBO INTERNATIONAL AIRPORT, JOHANNESBURG

PROJECT DETAILS

Over the past few years three contracts at the OR Tambo International Airport near Johannesburg have utilised recycled hot-mixed asphalt. Two of the projects, the first of which was carried out in 2006, used 10% reclaimed asphalt (RA) in their asphalt base mixes, while 15% RA was used in the third project during 2007.

The use of recycled asphalt was mainly aimed at reducing the impact of road construction and rehabilitation on the environment by reusing reclaimed asphalt in the mixes and thus reducing the load on new aggregate sources.

The first two contracts, which included the rehabilitation of the Yankee Taxiway and runway 03R, entailed the paving of just less than 105 000 tons of asphalt base, utilising around 10 500 tons of RA in the mix.

During the third contract the construction of Hotel Taxiway included 28 000 tons of asphalt base which contained 15% of reclaimed asphalt.

ASPHALT MIX DESIGN

The RA used in the mixes on these contracts was not supplied from a particular project, but consisted of previously stockpiled returned loads of asphalt as well as plant waste. This material was screened to pass the 26.5 mm sieve size, resulting in a fairly consistent grading. Due to the low recovered penetration (less than 10) of the RA, and the relatively low proportion added to the mix it was regarded as “black aggregate” which would not affect the binder properties in the mix.

Table 1 Typical gradings of RA, combined aggregates and the specified grading

| Sieve Size (mm) | Percentage passing | | |
|-----------------|--------------------|----------------------------|-------------------|
| | Typical RA Grading | Combined Aggregate Grading | Specified Grading |
| 26.5 | 100 | 100 | 100 |
| 19.0 | 95 | 92 | 85 – 95 |
| 13.2 | 90 | 82 | 71 – 84 |
| 9.5 | 85 | 72 | 62 – 78 |
| 6.7 | 79 | 60 | 52 – 69 |
| 4.75 | 70 | 50 | 42 – 60 |
| 2.36 | 50 | 32 | 30 – 47 |
| 1.18 | 33 | 20 | 21 – 37 |
| 0.600 | 25 | 14 | 15 – 30 |
| 0.300 | 19 | 11 | 11 – 24 |
| 0.500 | 13 | 8 | 8 – 19 |
| 0.075 | 8.7 | 6.4 | 5 - 12 |

A typical grading of the RA used in the mixes, as well as the combined aggregate grading and the specified grading are shown in Table 1.

The mix design was carried out using 40/50 pen bitumen and indicated an optimum binder content of 4.0% for the mix containing 15% RA. The results of various parameters in the mix design are presented in Table 2.

Table 2 Summary of mix design results

| Parameters | Mix design values | Specifications |
|--------------------------|-------------------|----------------|
| Filler/Bitumen ratio | 1.3 | 1.3 – 1.6 |
| Film thickness (microns) | 8.0 | > 7.5 |
| Binder absorption (%) | 0.4 | < 0.5 |
| Void content (%) | 5.0 | 4.5 – 5.5 |
| VMA (%) | 14.4 | >15 |
| VFB (%) | 65.4 | |
| Marshall stability (kN) | 12.0 | |
| Flow (mm) | 3.1 | 2 – 6 |
| Stability/Flow ratio | 3.9 | |
| Immersion Index | 97 | > 80 |

The results of performance related tests are summarised in Table 3. It is interesting to note that in the 4 point beam tests there is an increase in number of repetitions to failure in the specimens containing RA, indicating an improvement in the fatigue properties of these mixes. As can be seen, an emphasis was placed on tests to check the deformation resistance and fatigue properties of the asphalt base mix. Similar results were reported in studies submitted as technical papers at the 2006 ICAP Conference in Quebec.

Table 3 Summary of performance test results

| Performance requirements | Test type used | Performance test results | | |
|--------------------------|---|--------------------------|-----------------------|---------------------------|
| | | Asphalt base mix | Asphalt base + 10% RA | Asphalt base + 15% RA |
| Deformation resistance | MMLS on briquettes at 50°C wet (on cores) (mm) | 1.5 | 1.7 | 1.7 |
| | Dynamic Creep (MPa) | 19.1 | 29.8 | 27.2 |
| | Gyratory voids at 300 gyrations (%) | 2.5 | 3.5 | 3.1 |
| Durability | Modified Lottman (%) | 81 | 99 | 82 |
| | Air permeability (cm ² X 10 ⁻⁸) | 0.3 | 0.63 | 0.48 |
| Fatigue | 4 Point Beam Fatigue (at 220 micro strain) (repetitions to failure) | 145k | 4400k | 3100k @ 200 micro strains |
| | ITS(kPa) | 1185 | 1108 | 1104 |

MIXING AND PAVING THE RECYCLED MIXES

As already mentioned the stockpiled RA was screened to pass 26.5 mm and was fed into the asphalt mixing plant via one cold feed bin. The mixing was carried out at 160°C. Typical production per shift was 1000 tons and the mix was paved at a temperature of around 135°C. The mix was paved in thicknesses varying from 50 mm to 100 mm, with compaction being carried out using a roller train consisting of pneumatic, vibratory and static rollers.

SUMMARY OF EXPERIENCE GAINED

No problems were experienced in achieving COLTO requirements in terms of binder and void content variation. The recovered penetration of the mix was found to vary from 27 to 35. The deformation resistance as well as the fatigue properties of mixes containing 10% to 15% RA were found to be superior to similar mixes containing only virgin aggregate. The slightly stiffer binder that results from the addition of the RA with its aged binder could in fact be regarded as beneficial in this particular application in a heavy duty airport taxiway. Besides the environmental benefits there was also a small cost saving of around 5% in using the RA instead of importing new quarry aggregates.